

Summer Art

Week 5 lesson 5

Can I draw a face side profile?

Step 1 - Draw a Circle, a Square, and Intersecting Lines

We'll start in the same way that we did before by drawing a circle, two intersecting lines, and a square that makes contact with the circle at all four corners.

Here again, the top line of our square will become the hairline. The middle line will become the brow line and the bottom line will become the nose line.

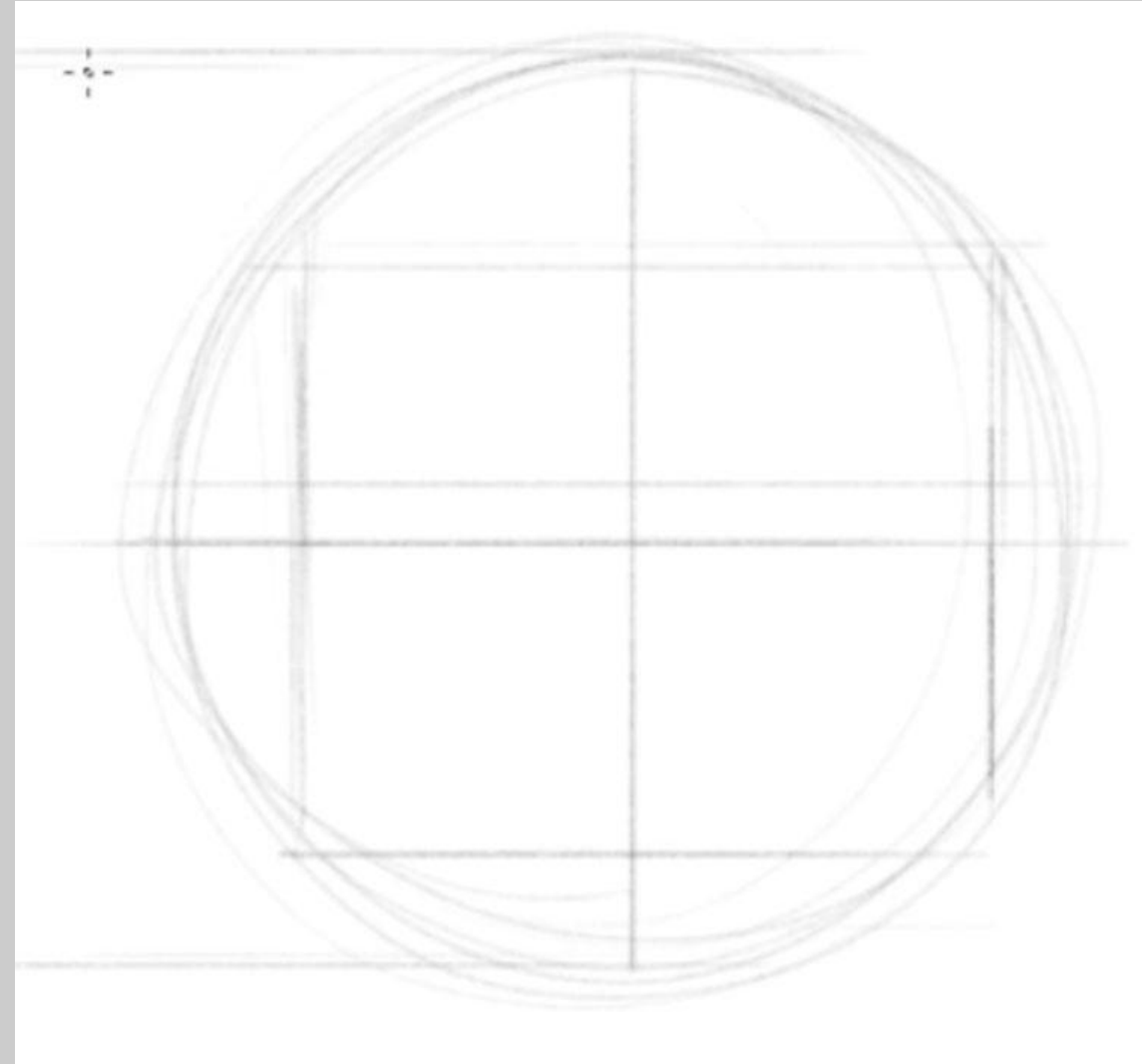

Step 2 - Draw a Line from the Top of the Head to the Chin

We'll next mark the location of the bottom of the chin. We can measure the distance from the centre of the square to the bottom and use this measurement to mark the bottom of the chin.

With a mark in place for the chin, we'll draw the front edge of the face. In this case, our subject is facing to the left, so we'll bring a curved line down from the top of the head to the bottom of the chin.

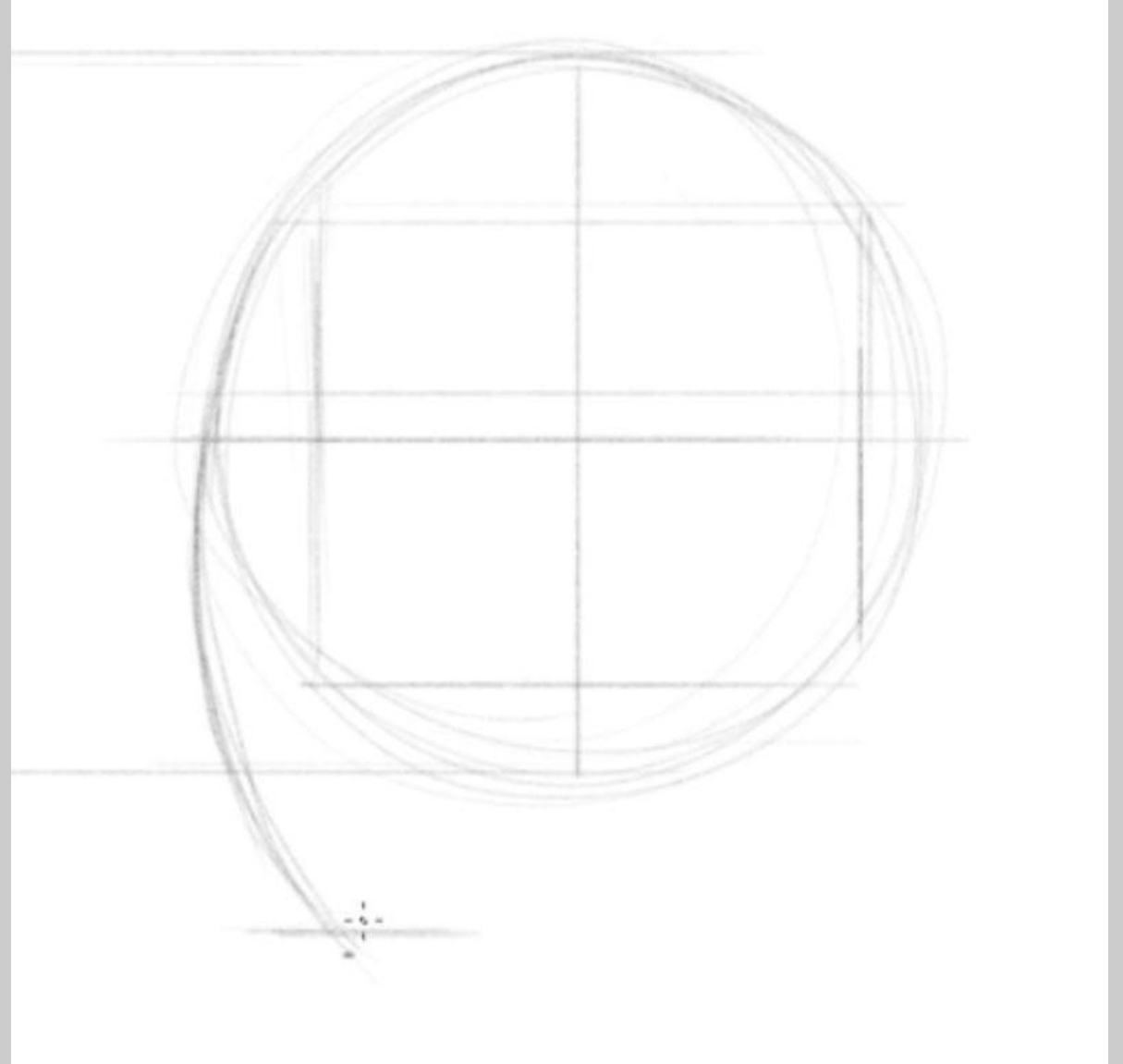

Step 3 - Add a Line from the Bottom of the Chin to the centre of the Square

Next, we'll draw a line from the bottom of the chin to the centre point on the bottom of the square. This line represents the jawline. This line will curve slightly in most cases.

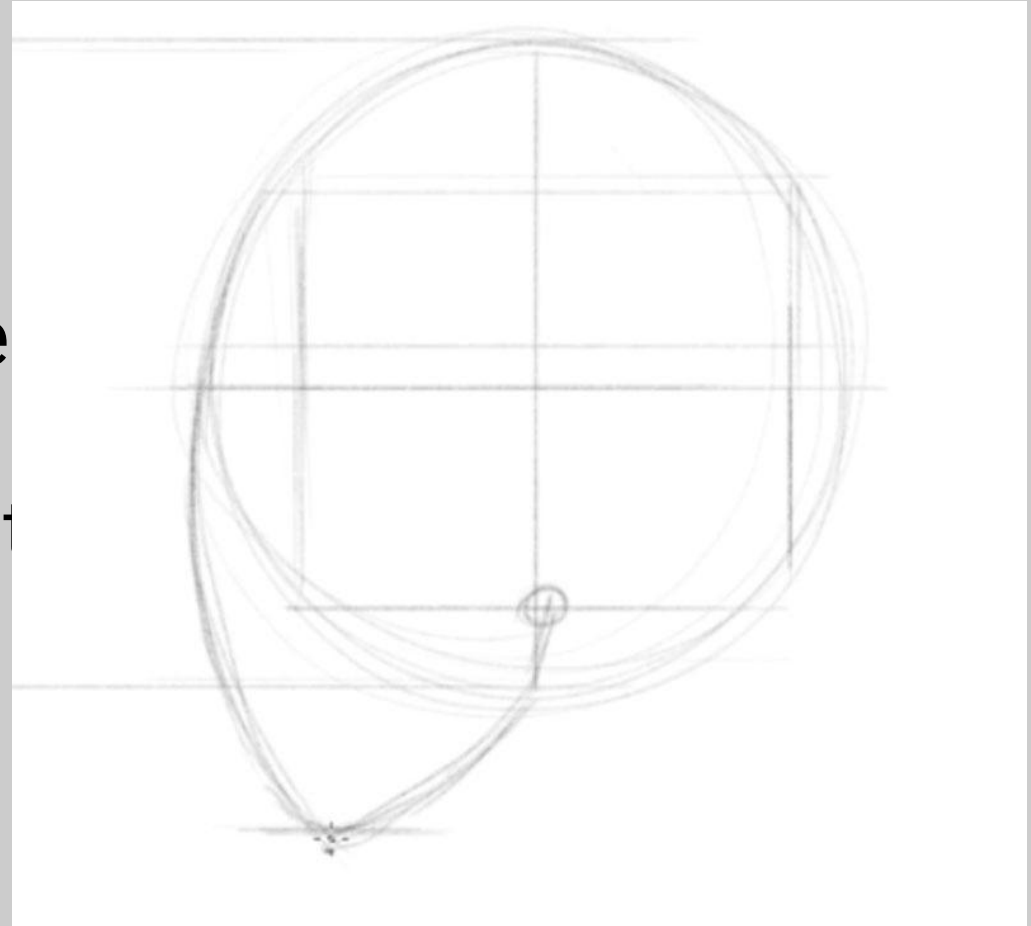

Step 4 - Determine the Location of the Eyes

Now we'll measure to the centre of the head and place a line to represent the eye line. Again, this line should be drawn just underneath the brow line.

We can also use the circle that we drew with the bottom of the square to draw the backside of the head. Think about the structure of the skull here as you draw this line.

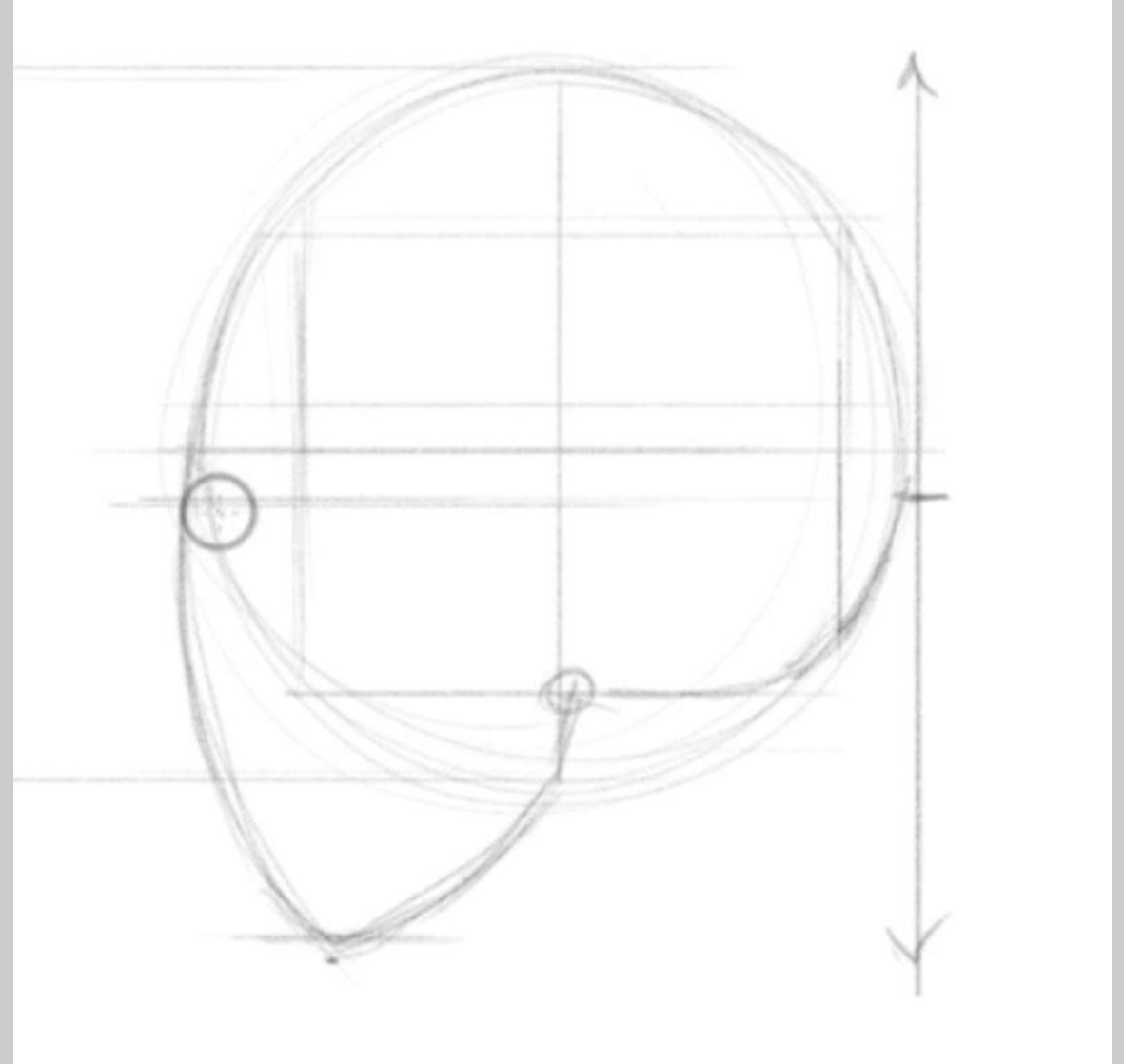

Step 5 - Draw the Facial Features and Add Shading

Now that we have an idea of the location of the facial features, we can draw them in using contour lines. We'll also add a bit of shading here to make the face have a sense of form.

Notice how the eyes are set back from the front edge of the face and how the lips and mouth recede at a diagonal towards the neck.

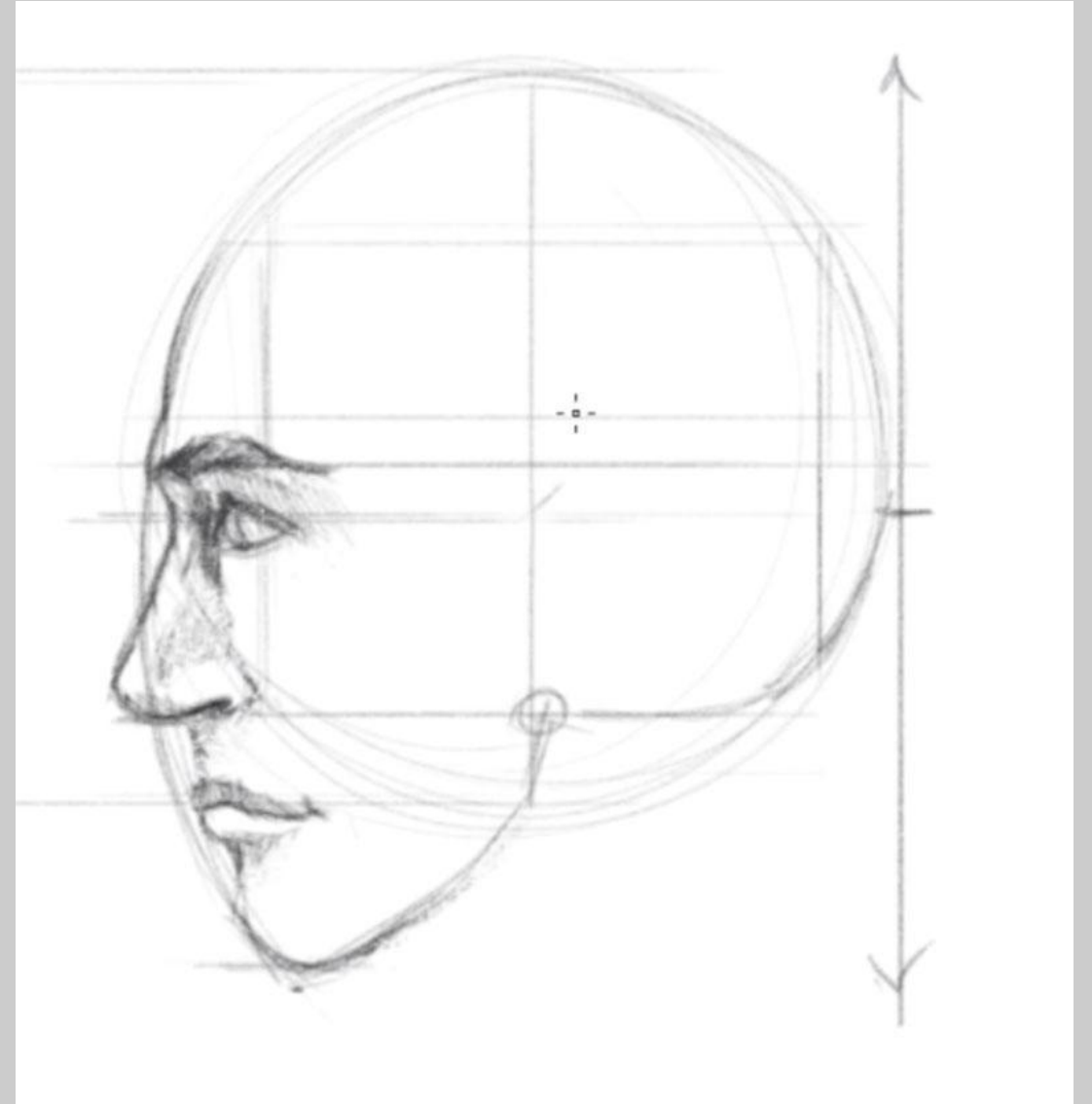

Step 6 - Draw the Ear on the Side of the Face

We can use our centre line, nose line, and eye line to draw the ear on the side of the face. Since our subject is facing towards the left, the bulk of the ear will be found on the right side of our centre line.

As we discussed before, the line drawn for the ear will start on the eye line, extend up to the brow line and then curve down, touching the nose line.

We'll also go ahead and draw a contour line for the outer edge of the hair and a couple of contour lines for the neck in this step.

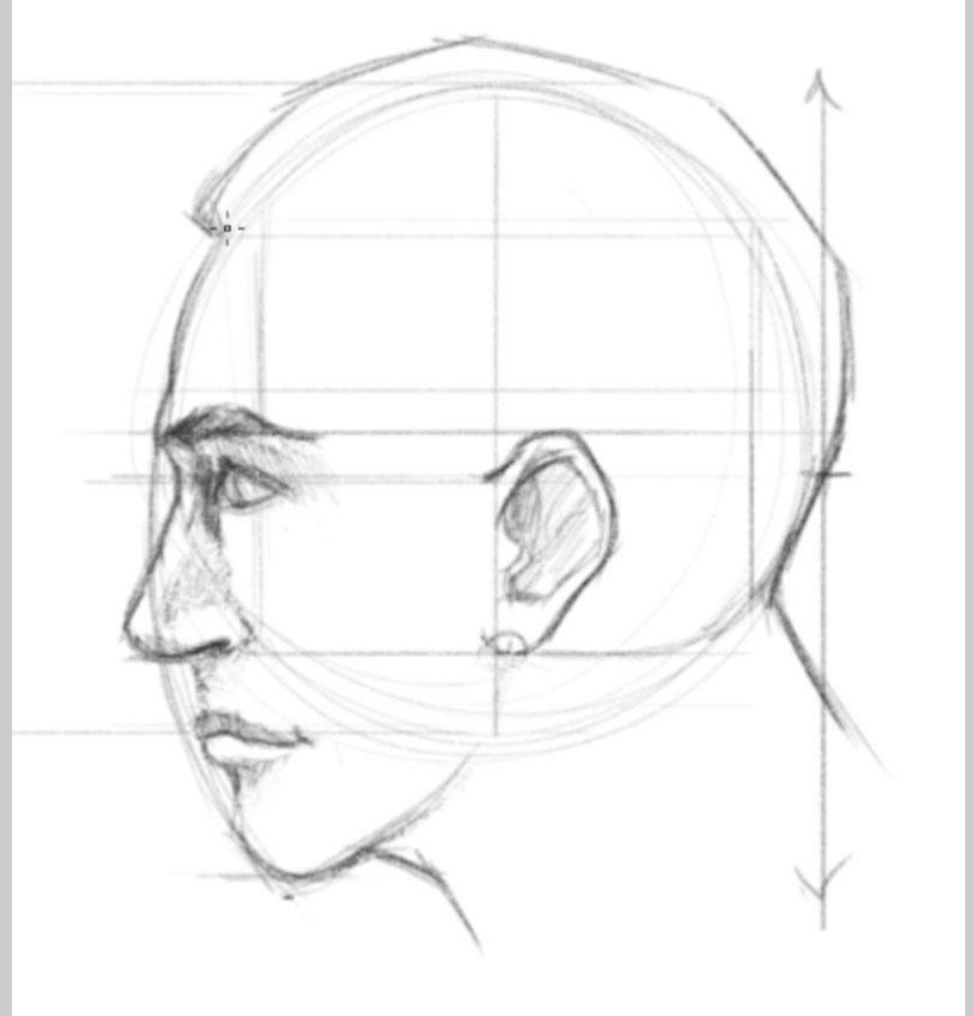

Step 7 - Add the Hair

We'll keep the hair style consistent with our first drawing and draw the hairline. In this case, the line extends back before making its way down to the ears.

We'll also add a few hints of shading to make the hair feel like a form.

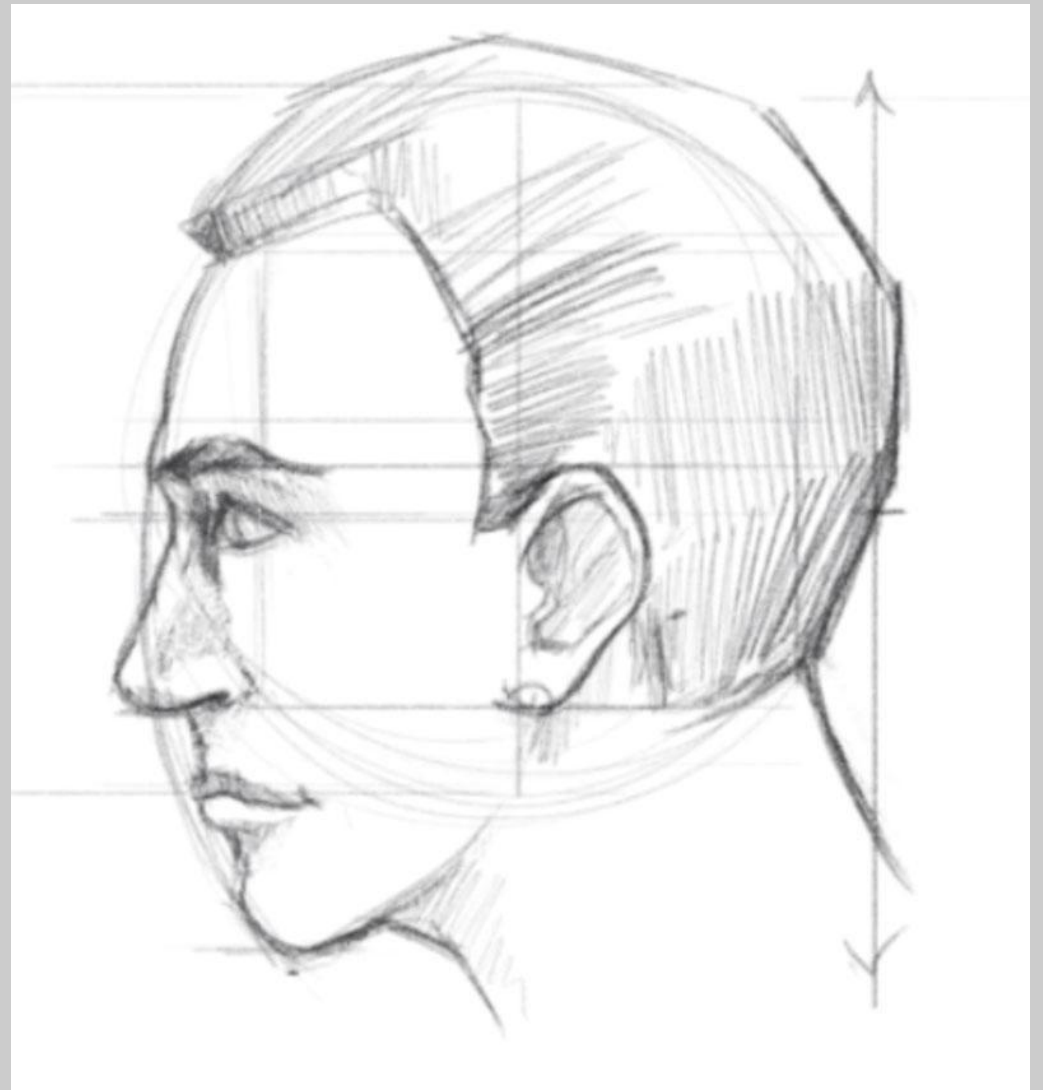

YOUR TASK: Like yesterday, either find a photograph of yourself or a family member (side profile) and sketch it.

Use these links to help you research drawing a face side profile:

<https://www.youtube.com/watch?v=07Q9pQJzWN8>

Please send us your drawings on the year 4 email address

year4@monkwickjunior.school